

ATTACHMENT 4 Boarding Service Requirements and Cost Schedule

Mortgagees should not board a property unless they have prior written approval from the M&M contractor, and/or:

- The property is severely damaged by fire, flood or other natural disaster;
- The property should be secured for safety reasons;
- The property is in a high vandalism area and boarding is the only reasonable means to protect the security of the property;
- The property is located in a pre-approved boarding area.

When boarding is appropriate, all first floor windows and doors and all basement windows and doors should have plywood covering the entire opening and frame. The covering should be secured with carriage bolts. Eliminate any health and safety hazard caused by any protruding bolts used to secure boarding. The use of nails is prohibited. The cost of boarding properties is not included in the maximum allowable limit per property. Before and after photographs are required. HUD will not reimburse the Mortgagee for unauthorized boarding. Mortgagees should request prior written approval from the M&M contractor if the cost of securing a severely damaged property exceeds \$550.

There should be no boarding above the first floor unless entry is possible without use of a ladder, and the opening is large enough for a person to easily pass through. Openings above the first floor that do not meet this test should be secured but not boarded. Second story and higher openings are typically accessible only from attached properties, stairwells or fire escapes. If security bars are located on windows/doors, boarding is not required. Openings too small for a person to pass through, particularly pet openings in doors, should be secured but not boarded. To ensure that no hazards exist, remove all broken glass from the windows and surrounding interior and exterior areas.

All properties should be boarded in accordance with local codes. If local codes differ from HUD requirements herein, local codes supersede.

For the purpose of this document, the definition of united inch is length plus width.

I. Specifications for Plywood Boarding

1. Exterior Plywood should be of un-sanded CDX grade.
2. Plywood thickness should be 1/2" for window openings, 5/8" for door openings and 3/4" for sliding door and French door openings. When extra large window openings are encountered use 5/8" or 3/4" as necessary.
3. All holes should be drilled to accommodate bolts. The holes in the top of the plywood should be 12" down from the top and 20% of the width of the plywood cover, in from the side.
4. The holes in the bottom should be 25% of the height of the plywood, up from the bottom and the same distance in from the side as the top.
5. Carriage bolts mated with nut and two three inch flat washers as shown in the side view. Washers to be of sufficient size to fully accept the square portion of bolt beneath head. Bolt and mating hardware may be galvanized or cadmium plated. 3/8" x 12" bolts should be supplied with each 2'8" door, 3'0" door, and glass sliding door cover. 3/8 x 10" bolts should be supplied with the rest.

6. 2" x 4" lumber should be graded and should be a minimum of 16" longer than the width of the plywood cover. (Note: 2x4s will be drilled with 1/2" diameter holes that line up with the holes in the plywood covers.)
7. All windows and doors, except the front door, through which access to the interior of the dwelling is made, should be secured. All window boards will be cut to fit inside the concrete block or brick opening with a maximum 1/8" clearance. THE PLYWOOD COVERING SHOULD BE OF ONE CONTINUOUS PIECE WHEN POSSIBLE.
8. All fabricated parts and ancillary materials become property of the Department of Housing and Urban Development.
9. All coverings are to be fabricated according to the attached drawing and specifications.

II. Boarding Windows

1. Except as noted below, all window sashes, frames, glass and hardware are to be undamaged by the boarding installation.
2. All screen inserts are to be removed, marked as to location and stored in a convenient closet or in the utility room.
3. In all cases where it is possible to adjust the position of the sashes to accommodate the specifications for boarding above, the sashes are to remain in the frame.
4. In instances wherein the sashes cannot be adjusted to accommodate the boarding specifications above, the sashes are to be removed from the frames and stored in a convenient closet or in the utility room. This includes all stationary lights secured by stops.
5. In cases wherein the sash cannot be removed and/or the frame is permanently built into the house and cannot be removed (i.e., Fenestra windows) it will be necessary to break the corner panes to accommodate the boarding and bolts. If the location of bolt holes, in the plywood, requires modification because of the muntin bar (a small bar that divides a windows glass), these locations are to be modified. In no case, in any type of window, is any sash or frame part to be damaged.
6. In all instances where items should be removed from the frame and stored, the items should be clearly marked as to the area from which it was removed.
7. All items are to be stored on edge and braced to prevent accidental tipping, sliding, etc. In no instance is any item to be stored laid flat.
8. Hinged windows are to be completely removed from the frame and stored as stated in (7) above. If possible the hinge pins are to be removed and remain with the removed item.
9. Faced nailing of panels to wood frame windows is prohibited.

Note: Costs below are per United Inch. Definition - United Inch equals length plus width.

Boarding Cost Schedule (NATIONWIDE)			
Boarding 1/2"	Boarding 5/8"	Boarding 3/4"	Screening
\$0.80	\$0.90	\$1.00	\$0.55

Local Variations from General Requirements

ATLANTA Homeownership Center

Illinois

Install cloth screening. Cloth screen first floor openings in zip codes:

60429 60426 60411 60466 60477 60443

Screening of wood windows is accomplished by framing the window with 2x2s. The screening is stapled over the frame and fastened with 1x2 furring laths.

Chicago, Illinois

Install Plywood boarding in the following pre-approved Chicago zip code areas following the Chicago boarding requirements below.

60608 60609 60610 60612 60615 60616
60617 60619 60620 60085 60621 60622
60623 60624 60627 60628 60636 60637
60643 60644 60649 60651 60653

Rule 1. All openings in a structure which may be accessed from ground level and/or within 8 feet in any direction of an exterior stairway, fire escape, ramp, porch or other exterior construction reachable from ground level or a public way should be secured to prevent entry by unauthorized persons. One building entrance should be secured with a door of either solid core wood or steel construction, having no window in the door, and the door should be securely locked to allow access only to authorized persons. Said door should be secured with a through-bolted hasp and padlock if the door swings in.

Materials

Rule 2. If plywood materials are used to secure buildings, such materials should be no less than 5/8-inch thick, exterior grade. Particleboard, wafer board, masonite or other similar materials should not be used for purposes of boarding-up a building.

Rule 3. Mechanical fasteners used for wood board-up materials should be round-head non-slotted carriage bolts no less than 3/8-inch in diameter with washers and nuts on the interior face.

Installation Methods

Rule 4. The primary method of securing plywood boards should be by the use of through-bolt compression fastening, using plywood on the exterior face and wood bracing constructed of minimum 2-inch by 4-inch (nominal) lumber installed on the interior side of the opening to be secured, perpendicular to the long dimension of the opening. Such bracing should extend at least 6 inches beyond the edge of the opening on each side in order to be securely braced against the building structure.

Rule 5. Wood construction used to secure a building opening should contain at least one bolt in each corner and additional bolts no more than four feet on center continuously along the perimeter. Each bolt should fully penetrate the wood bracing on the interior side of the opening.

Rule 6. In the event that the through-bolt compression fastening is impossible due to the construction or condition of the opening, the opening should be covered with plywood secured with minimum 3-inch-long wood screws fastened on 4-inch centers around the circumference of the opening.

Florida

Boarding is pre-approved in the following zip code areas:

Miami:

33004	33009	33010	33012	33013	33014
33020	33023	33034	33054	33055	33056
33060	33069	33122	33125	33127	33128
33130	33131	33132	33136	33137	33138
33142	33147	33150	33157	33161	33167
33168	33169	33170	33177	33181	33190
33311	33315	33316	33401	33403	33404
33405	33407	33426 (east of 1-95)	33435	33441	
33444	33460	33462 (east of 1-95)			

Exterior surface and edges of all plywood should be painted with one coat white primer and one coat white finish. Use of screws to secure panels to wood frame windows is prohibited. See plywood-boarding diagram on **page 27**.

Caribbean

Exterior surface and edges of all plywood should be painted with one coat white primer and one coat white finish. Use of screws to secure panels to wood frame windows is prohibited.

Additionally, boarding is pre-approved in the following zip code areas:

00923	00924	00929	00601	00602	00603
00703	00704	00705	00610	00612	00714
00616	00617	00794	00915	00956	00957
00959	00961	00622	00623	00725	00627
00729	00920	00921	00979	00982	00983
00985	00986	00987	00962	00736	00735
00935	00638	00739	00769	00782	00907
00783	00780	00926	00646	00647	00738
00650	00934	00652	00653	00784	00656
00965	00966	00967	00968	00969	00970
00971	00778	00659	00917	00660	00791
00662	00913	00664	00795	00777	00667
00669	00670	00771	00772	00911	00773
00674	00909	00606	00707	00680	00715
00676	00687	00718	00719	00720	00723
00624	00716	00717	00728	00730	00731

00734	00740	00741	00678	00677	00745
00925	00926	00927	00637	00688	00952
00751	00690	00683	00685	00757	00907
00909	00911	00912	00913	00953	00949
00976	00641	00692	00693	00901	00765
00766	00767	00698			

EXCEPTION: There is no pre-approved boarding in ANY gated community within these zip code areas.

PHILADELPHIA Homeownership Center

Connecticut

Boarding pre-approved in the following zip codes areas for the cities of:

Bridgeport: 06601 06604 06605 06606 06607 06608 06610 06611
06612 06614 06615 06650 06673 06699

New Haven: 06501 06502 06503 06504 06505 06506 06507 06508
06509 06510 06511 06512 06513 06514 06515 06516
06517 06518 06519 06520 06521 06524 06525 06530
06531

Massachusetts

Boarding pre-approved for the following zip code areas:

Boston: 02108, 02109, 02110, 02118, 02119, 02120, 02121, 02122,
02124, 02125, 02126, 02127, 02128, 02130, 02131, 02136

Brocton: 02401, 02402

Lawrence: 01840, 01841, 01842, 01843, 01845

Lynn: 01902, 01903, 01904, 01905

New Jersey

Boarding is pre-approved for the following zip code areas for the cities of:

Asbury Park: 07712

East Orange: 07017 07018 07019

Elizabeth: 07201 07202 07206 07208

Irvington: 07111

Jersey City: 07302 07304 07305 07306 07307 09308 07309 07310
07311 07395 07399

Long Branch: 07740

Newark: 07101 07102 07103 07104 07105 07106 07107 07108
07112 07114 07175 07182 07184 07188 07189 07191
07192 07193 07194 07195 07197 07198 07199

New Brunswick: 08901 08902 08903 09804 08905 08906 08922
08933 08988 08989

Patterson: 07501 07502 07503 07504 07505 07506 07507 07508
07509 07510 07511 07512 07513 07514 07522 07524
07533 07538 07543 07544
Plainfield: 07060 07061 07062 07063 07069

Boarding is pre-approved for the following zip code areas:

08016	08066	08096	08618	08608
08101	08102	08103	08104	08105
08232	08609	08610	08611	08611
08312	08302 (Bridgeton only)		08360 (Vineland only)	
08401	08406 (Ventnor only)		08110 (Pennsauken only)	
08600	08332 (Mellville only)		08650 (Trenton only)	

New York, New York

Board all properties within the city limits of the five boroughs in New York City without pre-approval with the exception of Dutchess, Putnam, and Rockland Counties.

Rhode Island

Boarding is pre-approved for the following zip code areas in the cities of:

<u>Providence:</u>	05901	02902	02903	02904	02905	02906	02907
	02908	02909	02910	02911	02912	02918	02919
	02940						
<u>Cranston:</u>	02823	02905	02907	02910	02920	02921	

Pennsylvania

Boarding is pre-approved for the following zip codes.

17509	17512	17516	17517	17518	17527
17532	17536	17547	17550	17560	17563
17565	18101	18102	18103	18115	18117
19013	19023	19320	19335	19380	19401
19464					

SANTA ANA Homeownership Center

Long Beach, California

Properties should be secured with window screens and security doors only. Do not use plywood boarding material to secure window openings. See diagrams and specifications on pages 30-31.

PLYWOOD BOARDING PANEL DETAIL

NO SCALE

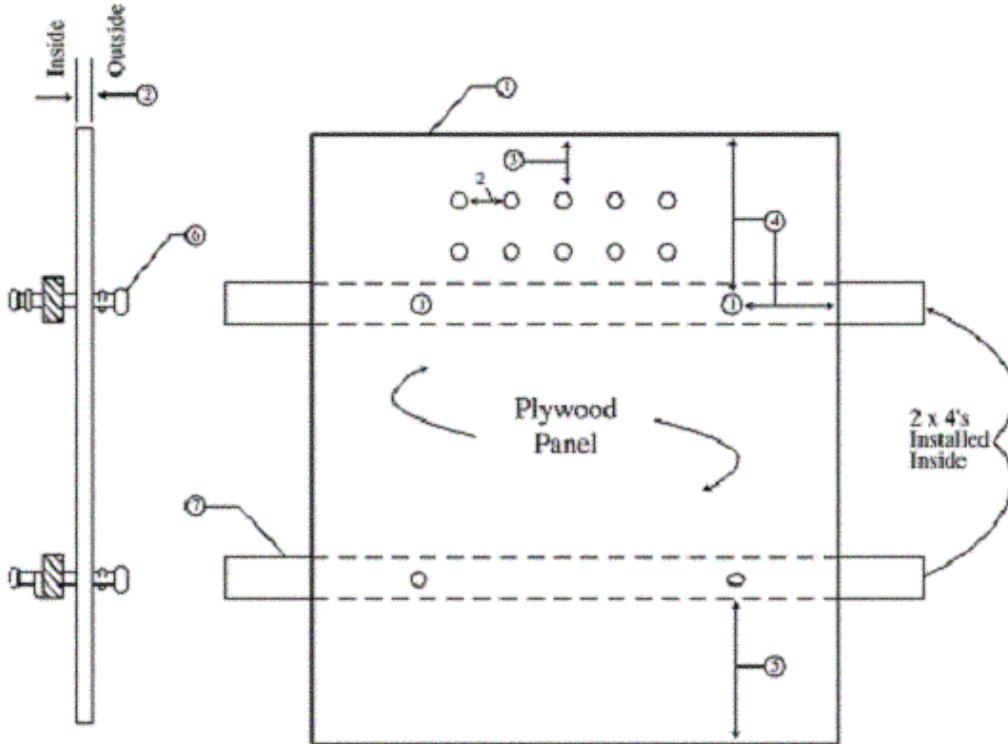

SECURING INSTRUCTIONS FOR WINDOWS

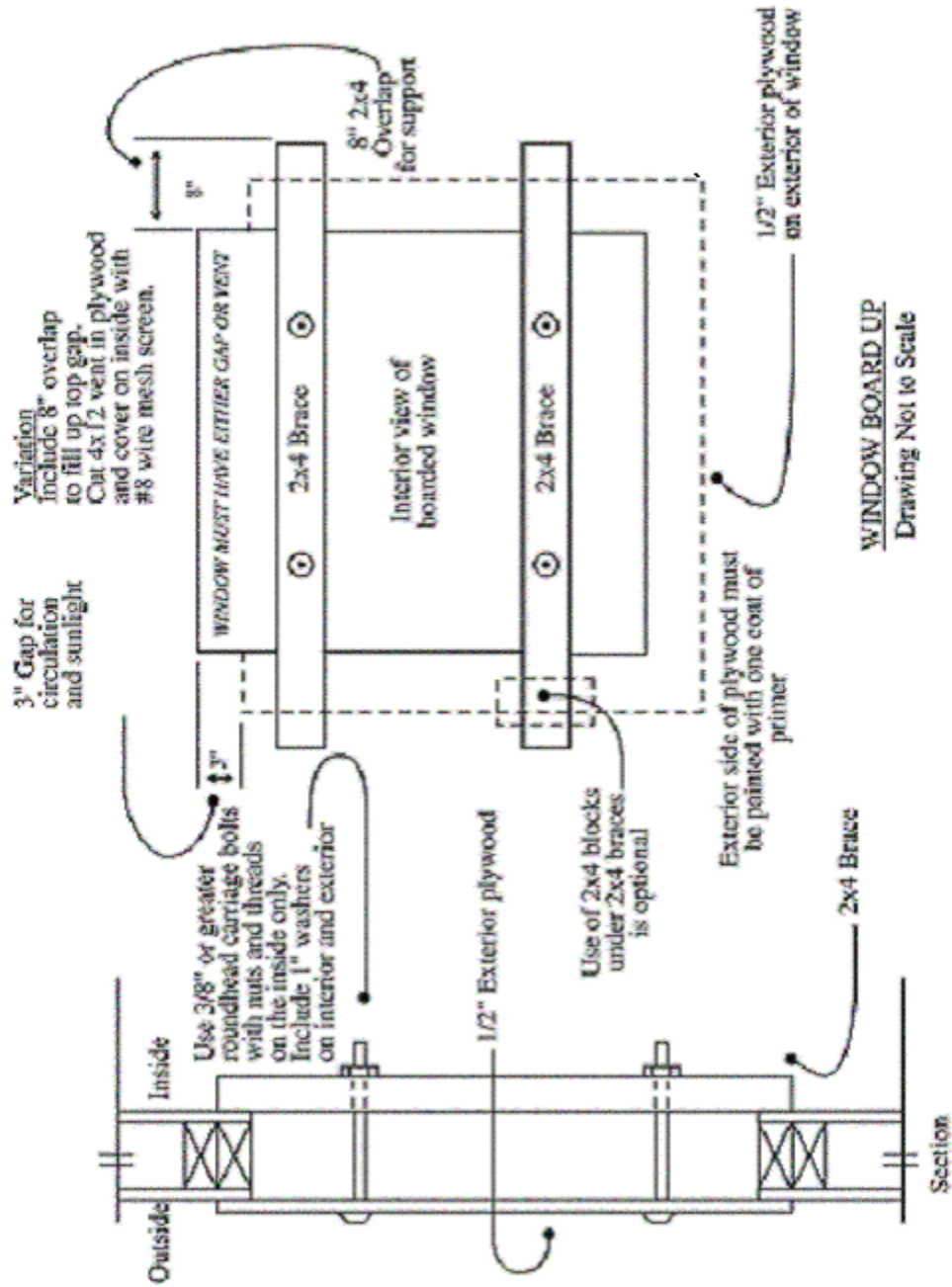

SECURING INSTRUCTIONS FOR DOORS

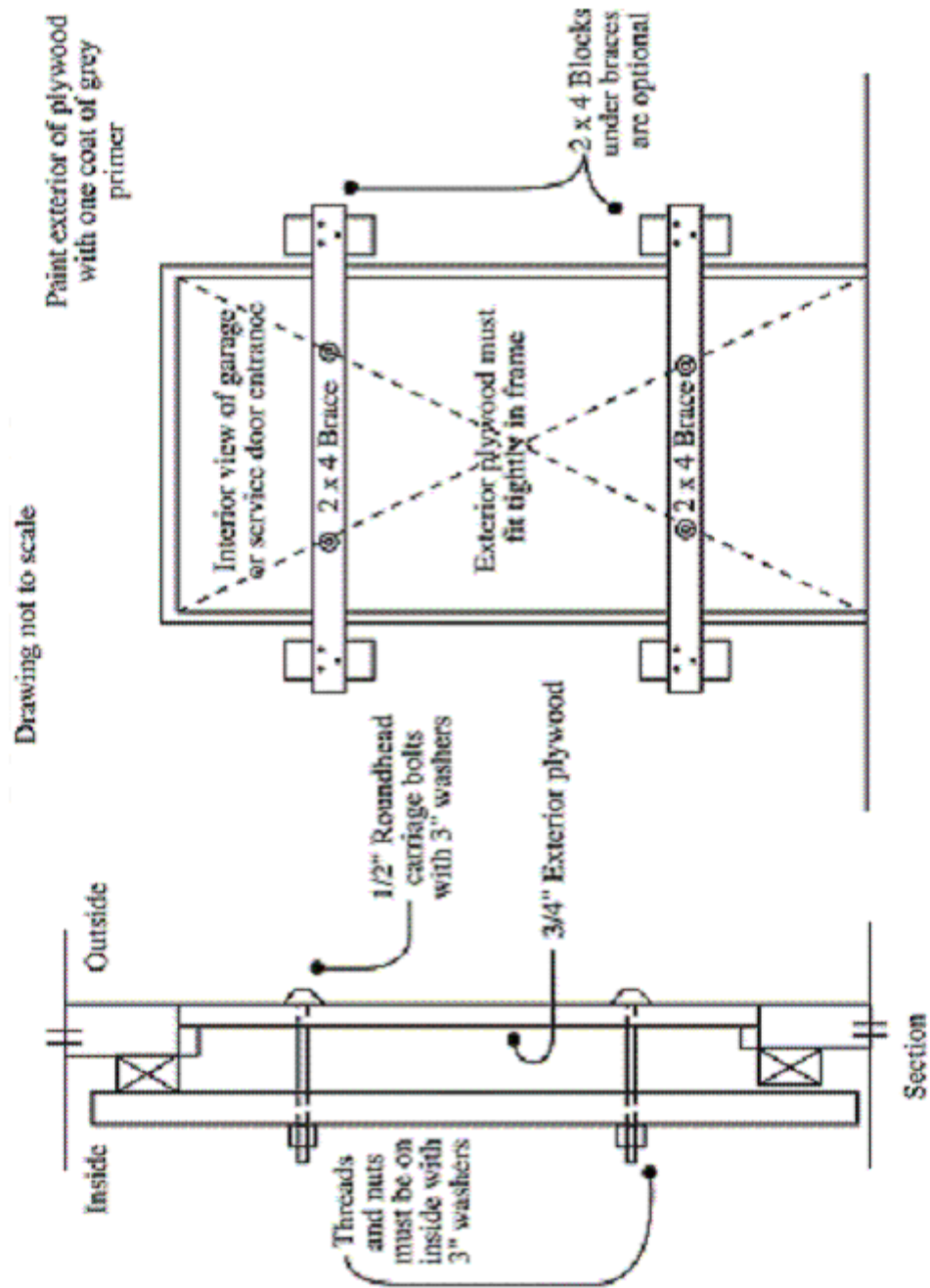

SECURITY SCREEN INSTRUCTIONS FOR LOS ANGELES OFFICE

SAMPLE SPECIFICATIONS

- I. SCREEN MODULE COMPONENTS MATERIAL DESCRIPTION
- (a) FRAME ELEMENT: 15/16" x 7/16" x .060" wall thick, 6063-T5 aluminum alloy extrusion.
- (Frame element has inherent locking feature that mechanically locks the security grille in place when assembled.)
- (b) SECURITY GRILLE: Plastic coated 1-1/2" x 3 diamond pattern 13 ga. and flattened carbon steel, (color grey)
- (Electrostatically coated vinyl powder that is temperature fused to form a thin film protective coating.)
- (c) INNER CORNERS: .100" thick 6061-T6 aluminum alloy
- (d) SPLINE: .185" vinyl, serrated.
- (e) SCREEN: 18/14 alclad aluminum screening.

- II. ATTACH HARDWARE MATERIAL DESCRIPTION
- (a) RESTRAINT BRACKET .062 thick 6061-T aluminum alloy (See Fig. I).
- (b) CHANNEL BRACKET .062 thick 6061-T aluminum alloy (See Fig. II).
- (c) CLEVIS PIN 1/4" dia. x reqd. length, cadmium plated steel.
- (d) QUICK RELEASE PULL PIN .060 dia. piano wire cadmium plated steel.

III. QUICK RELEASE PIN TYPES

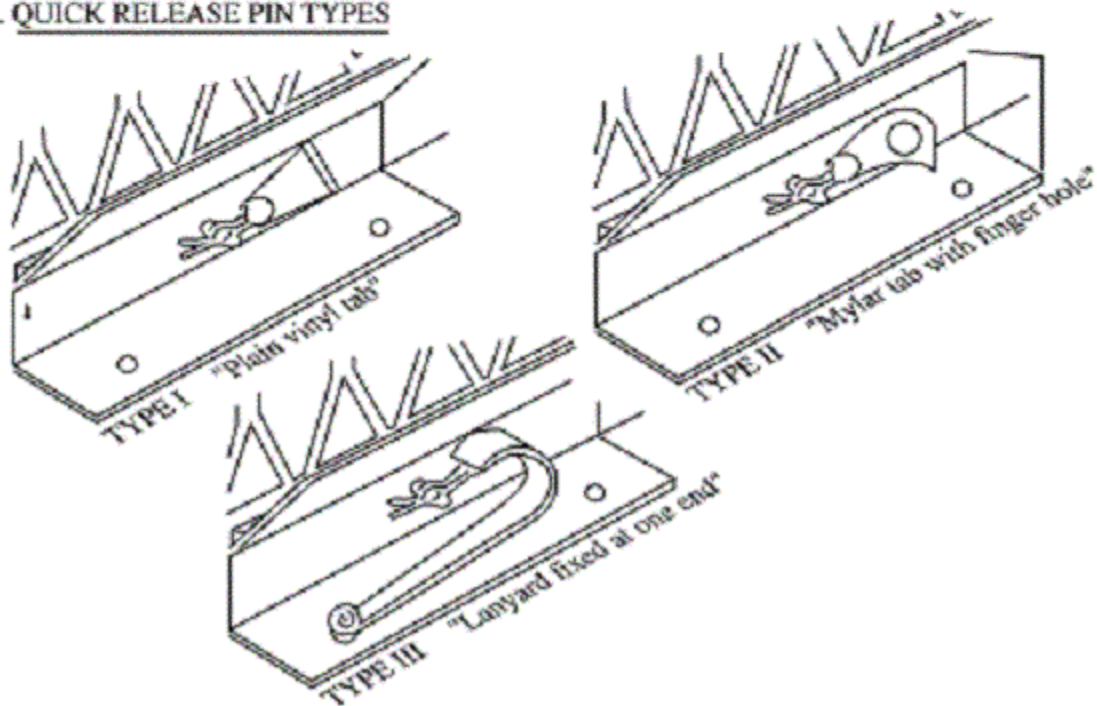

SECURITY SCREEN INSTRUCTIONS FOR LOS ANGELES OFFICE

IV. INSTALLATION

(a). DOUBLE HUNG WINDOWS:

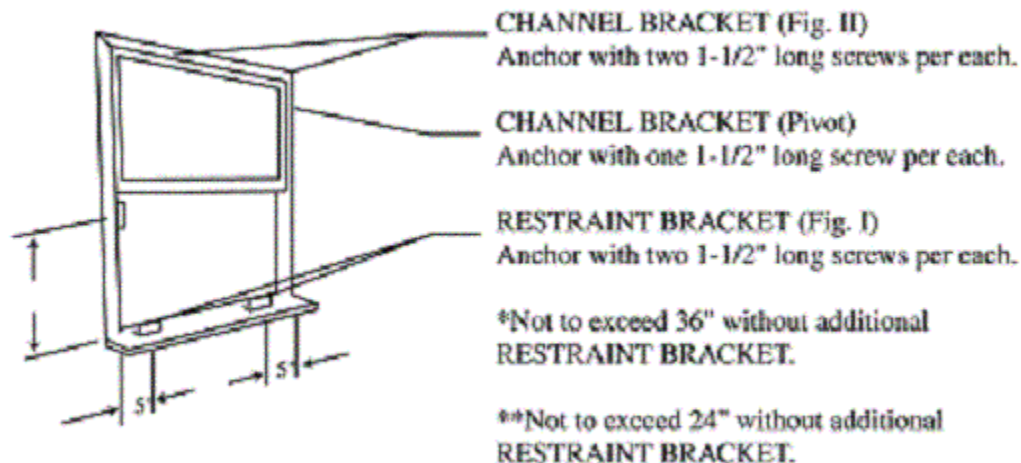

(b). **ALUMINUM SLIDER WINDOWS:** SECURITY SCREENS covering fixed windows are surface mounted and attached with tamper proof fasteners, set 6 inches from each corner and 18 inches on center along each side. There shall be a minimum of 2 fasteners per each side. SECURITY SCREENS covering sliding windows are surface mounted and secured with clevis and quick release pins that are accessible from the inside when the window is opened.

(c). **CASEMENT WINDOWS:** SECURITY SCREENS covering fixed and pivot windows are anchored to the existing window sash/frames with tamper proof fasteners, set 6 inches from each corner and 18 inches on center along each side. There shall be a minimum of 2 fasteners per each side. Where possible, the pivot window screen should be sized for outdoor/indoor convertibility, i.e., after occupancy, the screen can be installed on the inside.

